

FEB, FEC, FEX, FEY

600 VOLT/IN-LINE FUSE HOLDERS

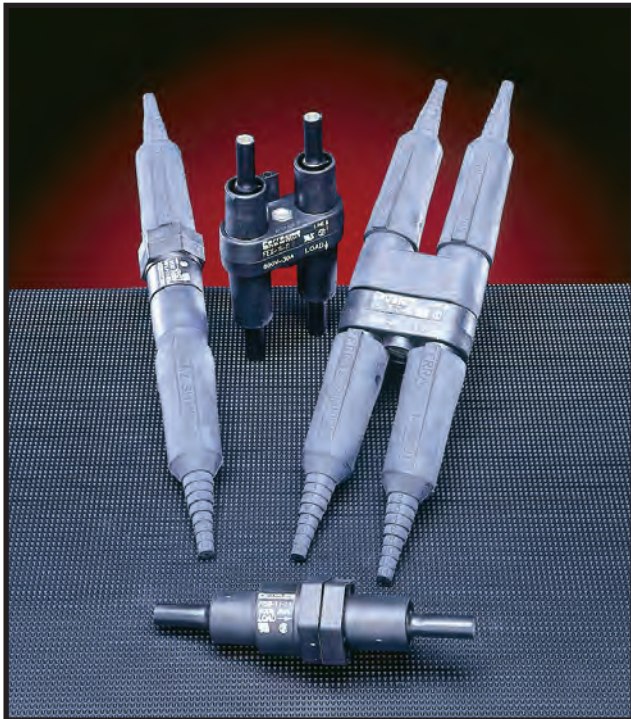

Ferraz Shawmut's complete line of single and dual pole in-line fuse holders accommodate either 1-1/2" x 13/32" (10x38mm) midget or Class CC fuses. The fuse holders are designed for quick installation. Securing nuts or screws are captive thus speeding installation by reducing the need to locate and assemble loose components in the field. Three internal O-rings per pole seal the fuse holder providing a water-resistant compartment for the fuse. The captive O-rings are colored (blue for single pole and red for dual pole) for quick detection. Optional cone shaped insulator boots can be slipped on to provide a watertight seal (breakaway versions come with boots standard). Both single and dual pole versions have an optional breakaway feature which safely disconnects the load in case of a pole knockdown. Fuses remain safely encapsulated within the watertight fuse holder on the load side. Once the pole has been reinstalled the fuse holder can be easily reconnected.

HIGHLIGHTS

- Breakaway version quickly disconnects line side during pole knockdown in compliance with state and federal highway commission standards
- 3 O-rings per pole for water tight applications
- Colored O-rings for quick detection
- Single and dual poles
- Accepts midget or Class CC fuses
- Wide assortment of terminal variations
- High heat, impact resistant insulator
- Captive nut or screw for quick installations
- Polarized dual pole provides simultaneous disconnection
- Permanently installed neutral versions quickly identified by white nuts
- Tulip fuse clip for improved contact and low losses
- Environmentally friendly-no lead solder used
- Highly visible catalog number even with insulation boots installed
- Wire gage size identified on insulation boots for quick, accurate trimming

APPLICATIONS:

- Street lighting
- Parking lot lighting
- Traffic signaling
- Sports lighting
- Boats and marinas
- Humid/corrosive environments



Ratings	Approvals
<ul style="list-style-type: none"> ➤ 600 VAC, 30A Short Circuit Current Rating: Midget Fuse 100kA, Class CC, 200kA ➤ Temperature Rating 155°C 	<ul style="list-style-type: none"> ➤ UL Listed Class CC Guide IZLT, File E52283 ➤ UL Recognized Component Midget Guide IZLT2, File E52283 ➤ CSA Certified Class CC and Midget Class 6225, File 32169



Recommended Fuse Usage

FEB and FEX holders will accommodate these Ferraz Shawmut Fuses:
Midget (1-1/2" x 13/32", 10 x 38mm): ATQ, ATM, TRM, OTM, GGU, GFN, A13X-2, A25Z-2, A60Q-2, A6Y-2B

FEC and FEY holders will accommodate these Ferraz Shawmut Fuses:
Class CC: ATDR, ATMR, ATQR

FEB, FEC, FEX, FEY

600 VOLT/IN-LINE FUSE HOLDERS

Catalog Numbering System

Family	Load Terminal		Line Terminal		Option	
	Type	Material	Type	Material		
FEB-	1	1	-	1	1	-BA

Nomenclature Legend

Family	Description	Load or Line Terminal Type							Option
		Terminal End View	Terminal	Type		No. Per Terminal	Solid	Stranded	Description
FEB	Single pole midjet		11	Cu Crimp	#8-#12 #12- #14	1 2	Yes Yes	Yes Yes	BA (breakaway version equipped with breakaway stud, breakaway boot, and insulating boots for both line and load sides)
FEC	Single pole Class CC		21	Cu Crimp	#10 #6 #4	2 1 1	Yes Yes Yes	Yes Yes No	
FEX	Dual Pole midjet		31	Cu Crimp	#10 #4	2 1	Yes No	Yes Yes	
FEY	Dual pole Class CC		41	Cu Crimp	#6 #2	2 1	Yes No	Yes Yes	
FEBN	Single pole neutral		81	Cu single Set Screw	#2-#12	1	Yes	Yes	
			91	Cu Double Set Screw	#2-#12	1 each	Yes	Yes	
			82	Al single Set Screw	#2-#12	1	Yes	Yes	
			92	Al double Set Screw	#2-#12	1 each	Yes	Yes	

Notes:

1. Non-breakaway units do not include insulator boots. These optional cone shaped boots are available to provide a watertight installation. The insulator boots are designed to form a watertight seal over conductors, but due to varying wire insulation sizes it is suggested that tape wrap be utilized for best results.

FSB1 = Single conductor boot (used to cover all crimp type & single set screw terminals)

FSB2 = Double conductor boot (used to cover all double set screw (Y-type) terminals)

Insulator boot trimming instructions: Locate wire gage size to be utilized marking on the boot and cut just beneath it.

2. Tightening torque for single and double set screw terminations: 35 lbs.-in.

3. Tightening torque for dual pole fastening screw: 10-15 lbs.-in.

4. FEBN versions have a permanently mounted dummy fuse for neutral applications.

FEB, FEC, FEX, FEY

600 VOLT/IN-LINE FUSE HOLDERS

Ferraz Shawmut In-Line Fuse Holder Family - Typical Combination Chart

Midget (10x38mm)	Midget (10x38mm) Breakaway	Class CC	Class CC Breakaway	Midget (10x38mm) Dual Pole	Midget (10x38mm) Dual Pole Breakaway	Class CC Dual Pole	Class CC Dual Pole Breakaway
FEB-11-11	FEB-11-11-BA	FEC-11-11	FEC-11-11-BA	FEX-11-11	FEX-11-11-BA	FEY-11-11	FEY-11-11-BA
FEB-11-21	FEB-11-21-BA	FEC-11-21	FEC-11-21-BA	FEX-11-21	FEX-11-21-BA	FEY-11-21	FEY-11-21-BA
FEB-11-31				FEX-11-31		FEY-11-31	
FEB-11-41	FEB-11-41-BA			FEX-11-41	FEX-11-41-BA	FEY-11-41	
	FEB-11-81-BA						
FEB-11-82	FEB-11-82-BA						
FEB-11-91	FEB-11-91-BA	FEC-11-91	FEC-11-91-BA				FEY-11-91-BA
FEB-11-92	FEB-11-92-BA						
FEB-11-S							
FEB-21-11							
FEB-21-21	FEB-21-21-BA	FEC-21-21	FEC-21-21-BA	FEX-21-21	FEX-21-21-BA	FEY-21-21	FEY-21-21-BA
FEB-21-91	FEB-21-91-BA						
FEB-31-31	FEB-31-31-BA						
FEB-41-41	FEB-41-41-BA						
FEB-81-81	FEB-81-81-BA	FEC-81-81	FEC-81-81-BA	FEX-81-81			FEY-81-81-BA
FEB-81-91	FEB-81-91-BA			FEX-81-91	FEX-81-91-BA		
FEB-81-S							
FEB-82-82	FEB-82-82-BA						
FEB-82-92	FEB-82-92-BA						
	FEB-91-91-BA						
FEBN-11-11	FEBN-11-11-BA						
FEBN-11-91	FEBN-11-91-BA						
FEBN-81-81	FEBN-81-81-BA						
FEB-SS							



Note: Consult factory for other configurations.

Crimping Tools Reference Chart, The following crimping tools (or equivalent) are recommended:

Terminal Type	FCI-Burndy	T&B
1	Y8MRB-1	WT-111M
2	Y2MR	TBM2/TBM5 BLUE DIE, WT-115-A DIE O
3	Y2MR	TBM2/TBM5 GREY DIE, WT-115-A DIE E
4	Y2MR	TBM2/TBM5 BROWN DIE, WT-115-A DIE F

FEB, FEC, FEX, FEY

600 VOLT/IN-LINE FUSE HOLDERS

FEB and FEC, Non-Breakaway and Breakaway Assembly Drawings

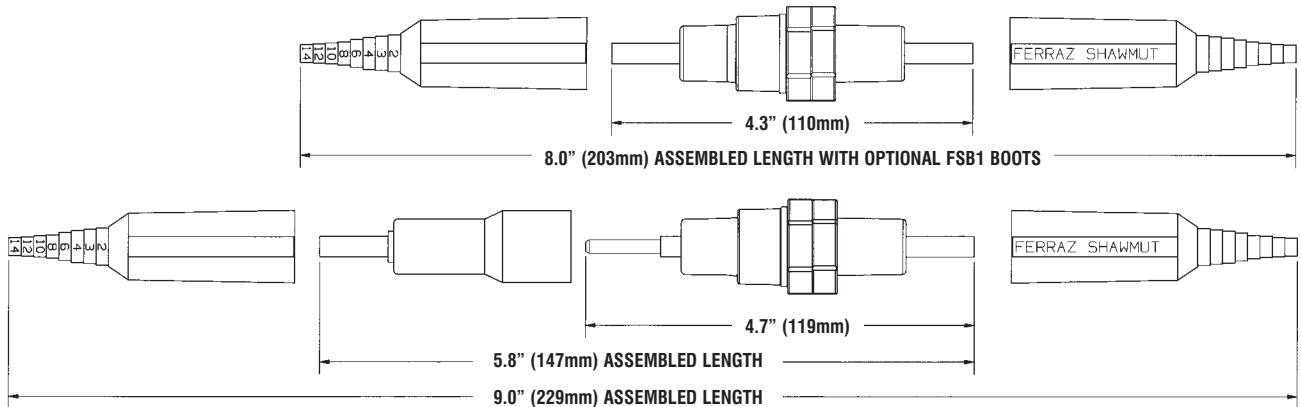

FEX and FEY, Non-Breakaway and Breakaway Assembly Drawings

